

✓

INSTRUCTION MANUAL

REGULATED DC POWER SUPPLY

MODEL PAE 35-30

KIKUSUI ELECTRONICS CORPORATION

83.7.28

833844

Power Requirements of this Product

Power requirements of this product have been changed and the relevant sections of the Operation Manual should be revised accordingly.

(Revision should be applied to items indicated by a check mark)

Input voltage

The input voltage of this product is _____ VAC,
and the voltage range is _____ to _____ VAC. Use the product within this range only.

Input fuse

The rating of this product's input fuse is _____ A, _____ VAC, and _____.

WARNING

- To avoid electrical shock, always disconnect the AC power cable or turn off the switch on the switchboard before attempting to check or replace the fuse.
- Use a fuse element having a shape, rating, and characteristics suitable for this product. The use of a fuse with a different rating or one that short circuits the fuse holder may result in fire, electric shock, or irreparable damage.

AC power cable

The product is provided with AC power cables described below. If the cable has no power plug, attach a power plug or crimp-style terminals to the cable in accordance with the wire colors specified in the drawing.

WARNING

- The attachment of a power plug or crimp-style terminals must be carried out by qualified personnel.



CONTENTS

	<u>PAGE</u>
SECTION 1. GENERAL	
1-1. Introduction	1
1-2. Specifications	2
1-3. Outline Drawing	6
SECTION 2. OPERATION	7
2-1. Conditions for Operation	7
2-2. Front and Rear Panel Descriptions	10
2-3. Operating Instruction	13
SECTION 3. OPERATING PRINCIPLES	17
3-1. Operating Principles	17
3-2. Protection Circuits	18
3-3. Block Diagram	20
SECTION 4. APPLICATIONS	21
4-1. Remote Sensing	21
4-2. Remote Programming of the Output Voltage	22
4-3. Remote Programming to Control the Current Output	25
4-4. On/Off Control of the Output by an External Terminal	29
4-5. Parallel Operation	30
4-6. Series Operation	31
4-7. Battery Charging	33
4-8. Cut Off of Power Supply Switch by External Terminals	34
4-9. Use of Card Edge Terminals	34
SECTION 5. MAINTENANCE	37
5-1. Routine Inspections and Adjustments	37
5-2. Symptoms and Causes of Operation Failures	37
SECTION 6. OPTIONS	40
6-1. Standard Racks and Installation	40
6-2. Installation of DPO	40
6-3. Crowbar	40
SECTION 7. INSTALLING THE DPO	42
* To Use The Guard Cap	51

SECTION 1. GENERAL

1-1. Introduction

Each model of Kikusui's PAE series is a high performance power supply unit produced after many years of research, which provides two opposite-natured functions: constant voltage supply and constant current supply, from a single unit. Therefore, we believe this series is ideal for integration into automatic measuring systems (ATE system).

Operation in the "Normal" mode is recommended for use as a constant voltage source, since this mode gives low output impedance and voltage with minor ripple. On the other hand, operation in the "Fast" mode is suitable for use as a constant current source or when high speed programming is necessary, since 100 to 1000 times sharper pulse rise times as well as decay (drop-off) times are available. Switching from/to the constant voltage mode to/from the constant current mode is made very easily with a single switch manipulation. The mode of operation will be displayed by a LED on the front panel.

Also, the installation of the high resolution potentiometers enables one to set desired values of voltage and current with high precision.

Combined use of the output switch and the C/Y limit switch enables one to preset the output value. Also, the built-in overvoltage protection circuit is also designed so that pre-setting may be made with the voltage meter on the panel.

Large easily read meters ($\pm 1.5\%$ of F.S) are installed on the panel. A variety of terminals are installed on the back panel for various applications. For the consideration of use as a terminal unit of a computer system, each model has the structure to internally mount Kikusui's DPO series option which consists of a GP-IB interface unit and a D/A converter.

1-2. Specifications

(Values shown below are typical values unless noted otherwise.)

Input

Input source: 108-132 volts, single phase 50/60 Hz.
Current consumption: 22A with the load in the rating value under 120V AC.
6.5A when short-circuited under 120V AC.

Output

Output voltage range: 0-35V
Voltage adjuster: 10 turn potentiometer with 6mV resolution.
Output current range: 0-30A
Current adjuster: 10 turn potentiometer with 8mA resolution.
Sink current: 5A

Constant voltage characteristics

Regulation (source effect): Max. 2.0mV against $\pm 10\%$ variation of input voltage.
Load effect: Max. 1.0mV against 0 - 100% variation of output current.

NOTE: These values are measured at the sensing terminals.

Ripple and noises: Normal Max. 0.4mV rms (5Hz-1MHz)
2.0mV p-p (0-10MHz)
Fast Max. 3.0mV rms (5Hz-1MHz)
50.0mV p-p (0-10MHz)

NOTE: Measurement is made by grounding either the positive or negative output.

893847

Transient responses: Normal 100 μ sec. 5-100% change

Fast 300 μ Sec. 5-100% change

NOTE: These are recovery time within a value of 0.05% of output voltage plus 10mV, or less.

Temperature coefficient: 50ppm/ $^{\circ}$ C

Programming speed: Rise time 100 μ sec. (for 0-35V)

Constant current characteristics

Regulation (source effect): Max. 1.0mA against \pm 10% variation of input voltage.

Load effect: Max. 3.0mA against 5-100% variation of output voltage.

Ripple and noises: Normal Max. 5.0mA rms (5Hz-1MHz)
20.0mA p-p (0-10MHz)

Fast Max. 10.0mA rms (5Hz-1MHz)
50.0mA p-p (0-10MHz)

Temperature coefficient: 200ppm/ $^{\circ}$ C

Programming speed: Rise time 150 μ sec. (for 0-30A)

Meters

Accuracy: \pm 1.5% of full scale

Voltmeter full scale: DC 40V

Ammeter full scale: DC 30A

Constant voltage operation mode display

Green LED

Constant current operation mode display

Red LED

Attached circuit

C/V limit switch: Limit value of constant voltage and constant current are indicated on the meters.

0179978

Output switch: Output voltage when this circuit is turned off--Max. $\pm 0.1V$

Orange LED is lit when this circuit is operating.

OVP circuit: Its function is to cut off the power supply by means of a circuit breaker.

The voltage range can be set from: 6-38V

Operating pulse width: 200 μ sec.

The pulse width of the voltage is 10% over the limit value necessary to actuate the OVP circuit.

Temperature protection

Up to 100°C with use of the Heat block.

Cooling method

Forced air cooling by means of fan.

Output polarity

Positive or negative grounding.

Anti grounding voltage

$\pm 250V$ DC

Insulating resistance

Between chassis and power source: Min 30 M Ω (DC 500V)

Between chassis and output terminal: Min 20 M Ω (DC 500V)

Operating ambient temperature range:

0-40°C

Operating ambient humidity range:

10%-90% RH

Input line fuse

Rating value: 30A

Dimensions: 10.3 ϕ \times 38mm

833849

Output fuse

(Source side) Rating value: 30A
Dimensions: 15 ϕ × 50mm

(Sink side) Rating value: 5A
Dimension: 6.4 ϕ × 32mm

Dimensions

See 1-3. Outline drawing.

Weight

40kg

Attachments/Accessories

Operating manual (1)

Extra input power source fuse (1)

Input power source cable (1)
L: 3m. ϕ : 5.5 mm²

Guard cap (one set)

0000000000

1-3. Outline Drawing

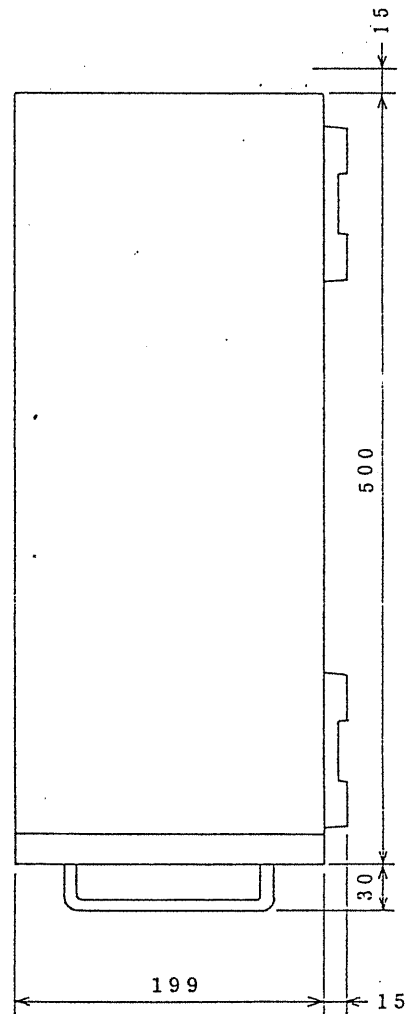
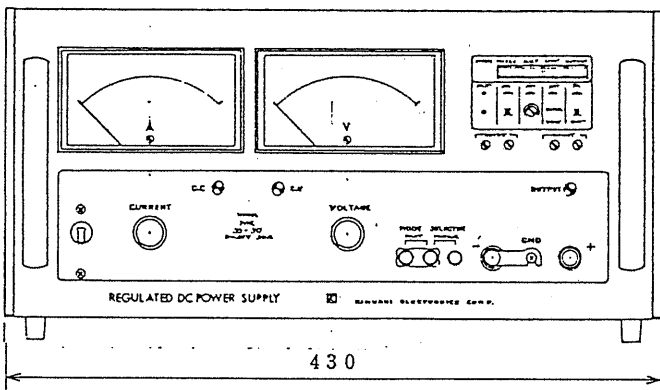
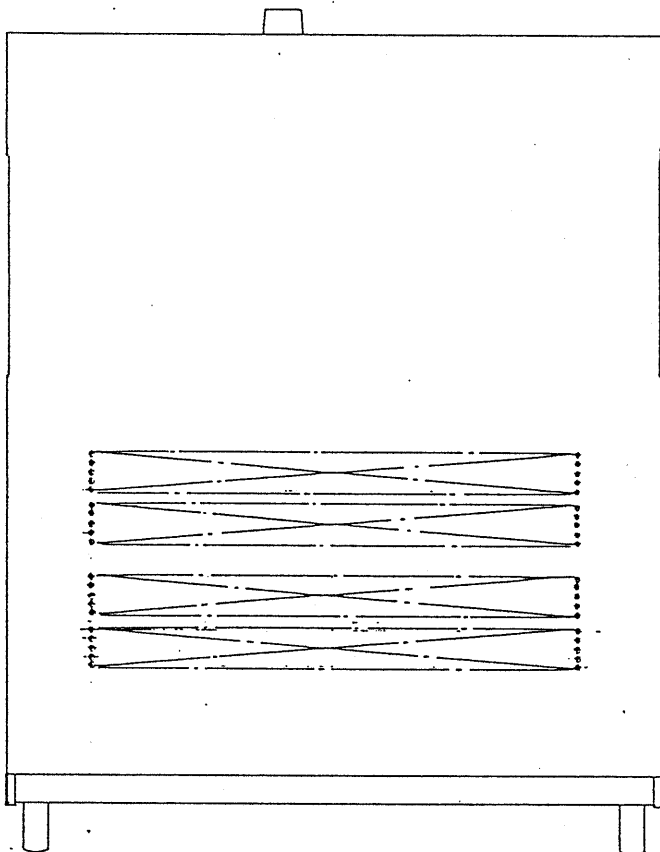
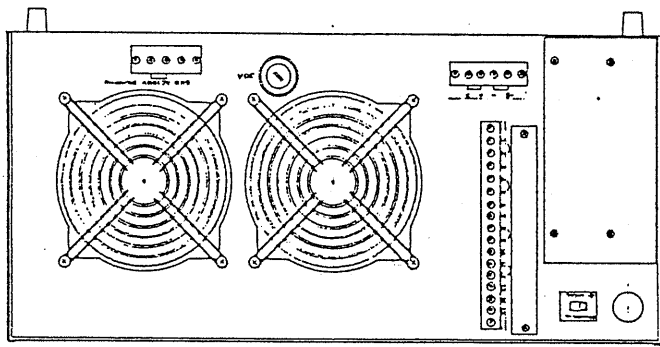

Unit: mm

FIG. 1-1

833851

SECTION 2. OPERATION

2-1. Conditions for operation

1. Power Requirements

Voltage range: 108-132 volts (single phase)

Cycle range: 50-60 Hz

Fuse capacity: 30 Amperes

2. Power Supply Cable

When it is necessary to extend the length of the power supply cable, select a correct plug and cable wire paying attention in terms of applied voltage, Joule heat to be generated by running current and voltage drop.

Consumption current: 22 Ampere with 120 volts AC.

Specific resistance of copper cable (made of soft copper).

Cable Cross-section	Specific Resistance (at 20°C)
1.25 mm ²	15 ohms/km
2.00 mm ²	9 ohms/km
5.50 mm ²	3 ohms/km
8.00 mm ²	2 ohms/km

Example: If 8 mm² cable is used in a 10m length, the total resistance will become 0.04 ohm for a round trip of 20m. Therefore, in the case of the PAE 35-30, a voltage drop of 1.2 volts will result. Accordingly, when line voltage is low, its effect may not be negligible.

3. Ambient Temperature Range

Ambient temperature should be within the range between 0°C and 40°C for sound operation. Operation at a temperature over 40°C would bring earlier deterioration of the components. On the other hand, operation at a temperature below 0°C may cause circuit instability.

4. Conditions of Installation Site

- . The ventilation openings on the top and bottom panels should not be covered.
- . Heated air is expelled from the fan blow-out. Do not leave heat sensitive material in front of it. Also, the instrument should not be operated within 30 cm of the wall.
- . Avoid a surrounding where it is very humid and/or dusty.
- . Avoid a place where there is disturbing vibrations.
- . Do not put a precision sensitive instrument with high precision on or beside the unit.

5. Normal/Fast Mode Switching

Switching from/to "Normal" mode to/from "Fast" mode must be performed after the output voltage is lowered by either turning off the power supply switch.

6. Load with Inductance and Capacitance

When constant current supply operation is made to a load with high inductance under the "Fast" mode, oscillation may be caused due to phase rotation. These problems may be solved by attaching a phase advancing condenser to the load or by switching to the "Normal" mode. If a condenser which has small impedance in high frequency ranges is attached to the output terminals under the "Fast" mode, oscillation may be caused depending on conditions of the load.

7. Overshoot Occurring when Power Supply Switch is Turned On.

Overshoot voltage of about ± 0.5 volts will appear for several milli-seconds when the power supply switch is turned on with a small load supplied. If this is a problem, the load should be

attached after the power supply switch is turned on and the output switch is turned off, and the problem will be avoided.

8. Others

Do not operate the unit without the cover. Operation without the cover will lower the fan's cooling efficiency, and could cause malfunction due to overheating depending on the output condition. Also, it is dangerous because odd material may drop into the unit and cause a short circuit to occur which may damage the unit.

Since the output circuits of this unit are designed in a complimentary connection, if a power supply source of higher voltage than that of the output is connected, the current from the power source continues to be absorbed into the unit. It is not good in terms of internal heat generation. As for parallel operation of a number of units with a battery load, refer to SECTION 4, 5. Parallel Operation and SECTION 4, 7. Battery, and follow the descriptions.

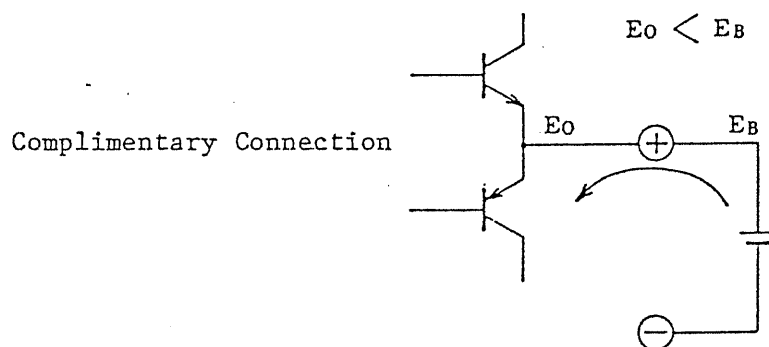

FIG. 2-1

833854

2-2. Front and Rear Panel Descriptions:

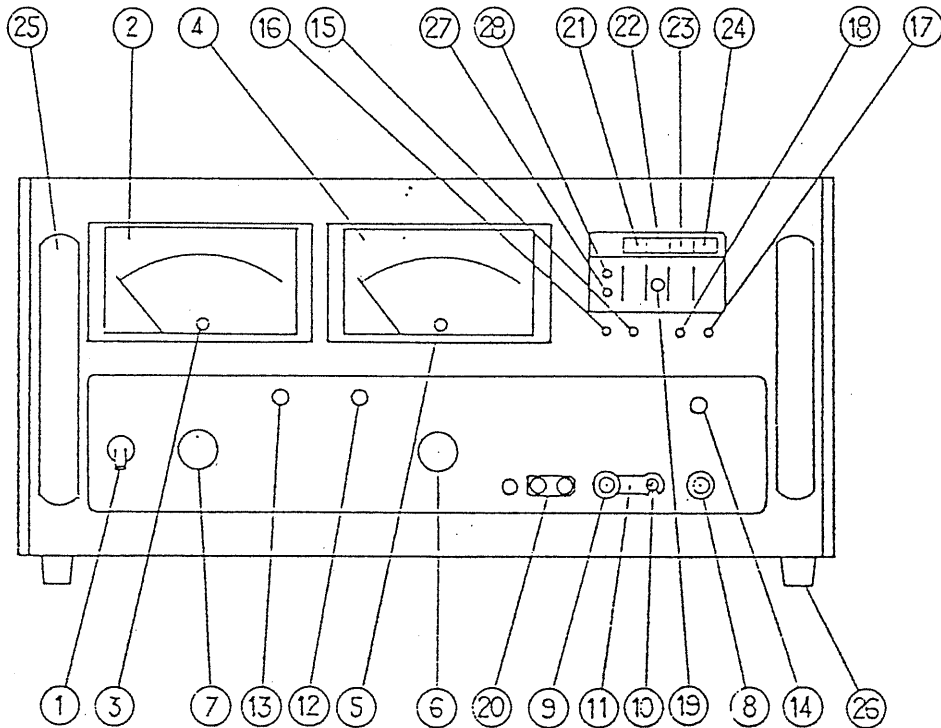

FIG. 2-2 Front Panel

- | | | | |
|---|----------|---|--------|
| ① | POWER | Power supply switch | |
| ② | <u>A</u> | Ammeter (Grade 1.5) | |
| ③ | | Ammeter zero adjustment | |
| ④ | <u>V</u> | Voltmeter (Grade 1.5) | |
| ⑤ | | Voltmeter zero adjustment | |
| ⑥ | VOLTAGE | Voltage control (10 turns) | * Note |
| ⑦ | CURRENT | Current control (10 turns) | * Note |
| ⑧ | + | Positive output terminal (red binding post) | |
| ⑨ | - | Negative output terminal (white binding post) | |
| ⑩ | GND | Terminal for grounding | |
| ⑪ | | Short bar | |
| ⑫ | C.V. | Constant voltage mode LED display (green) | |

- ⑬ C.C. Constant current mode LED display (red)
- ⑭ OUTPUT Output LED display (orange)
- ⑮ METER V Voltmeter sensitivity adjustment
- ⑯ METER A Ammeter sensitivity adjustment
- ⑰ OFFSET C.V. Constant voltage offset adjustment
- ⑱ OFFSET C.C. Constant current offset adjustment
- ⑲ OVP trip voltage adjustment
- ⑳ MODE SELECTOR Select the jumper connecting
- ㉑ METER Meter (indicator) switch (lock type)
- ㉒ OVP OVP voltage setting switch (non-lock type)
- ㉓ LIMIT Voltage/current limit switch (non-lock type)
- ㉔ OUTPUT Output switch (lock type)
- ㉕ Holder
- ㉖ Rubber foot
- ㉗ FAST indicator (RED)
- ㉘ NORMAL indicator (GREEN)

* Note: See on page 51.

833856

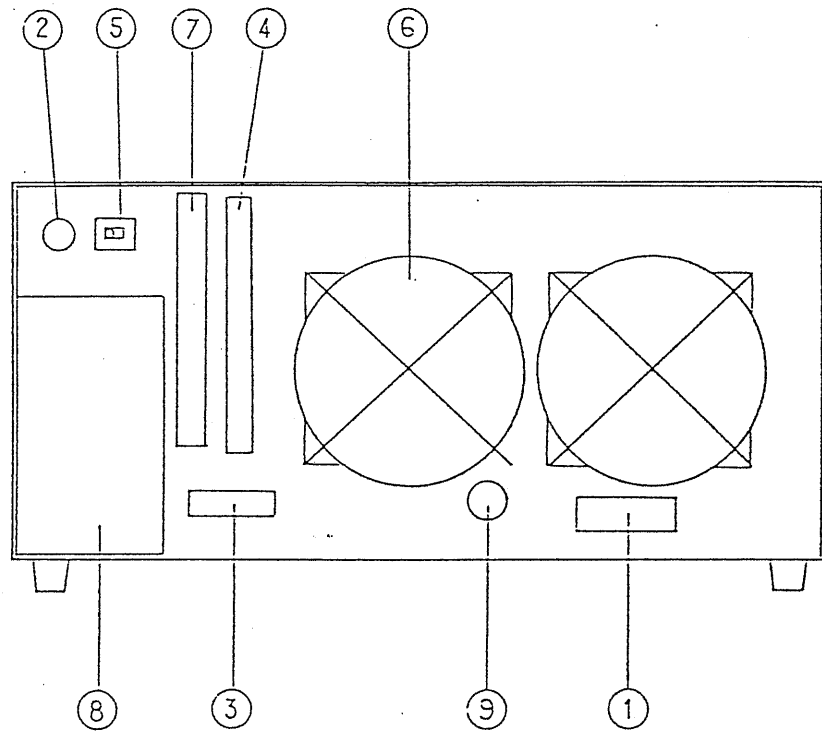

FIG. 2-3 Rear Panel

- ① Input terminal base (3p)
- ② Cap (Hole for modification)
- ③ Output terminal and sensing terminal base
- ④ Application terminal base
- ⑤ Remote/local switch
- ⑥ Ventillator
- ⑦ Cover 1
- ⑧ Cover 2
- ⑨ Input line fuse

933857

2-3. Operating Instruction

1. Check of Operation Under Standard Conditions

Step 1. Make sure that the shorting bars of the terminals on the back panel are connected securely as indicated by FIG. 2-4. Also, set the remote/local switch to "Local".

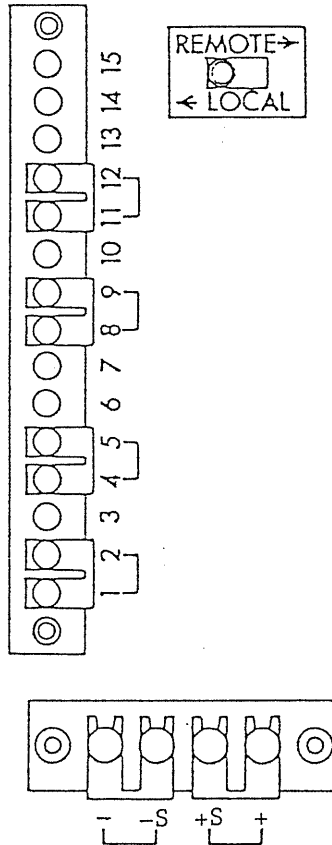

FIG. 2-4

- Step 2. Push on output switch (24) only, while leaving switches (20), (21), (22), and (23) turned off. For normal use, set the mode selector to NORMAL.
- Step 3. Turn the constant voltage dial (6) counterclockwise to the extreme position, and turn the constant current dial (7) also counterclockwise until you are 1 - 2 turns from the extreme position.
- Step 4. Turn the power supply switch (1) on, the C.V LED (12) (green), the output LED (14) (orange) and NORMAL MODE lamp will light and the fan will start running.

03000000

- Step 5. Watch the voltage meter (4) to make sure that the output voltage is increased to the maximum value of 35 volts while turning the constant voltage dial 6 clockwise. Then, turn off power supply switch (1).
- Step 6. Short-circuit the (+) and (-) output terminals with copper wire of 8mm² or more in size.
- Step 7. Turn the constant current dial (7) counterclockwise to the extreme position and then turn on power supply switch (1), the C.C.LED (13) (red), the output LED (14) (orange) and NORMAL MODE lamp will light.
- Step 8. Make that the output current is increased accordingly up to the maximum value 30 ampere, as the constant current value dial (7) is turned clockwise. Then, turn off power supply switch (1).

2. Definition of Operation Controls

1) Mode Selector (20).

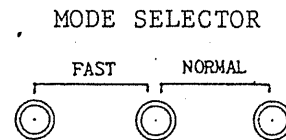

A good power supply unit should not only have low output impedance but also good dynamic stability against resistance load as well as capacitor/inductor load. Considering this, a constant voltage power supply unit generally installs a condenser between the output terminals to get low output impedance and to avoid large voltage drops due to an acute change in the load.

However, when the same unit is used as a constant current supply, the condenser installed at the output terminals will worsen the constant current characteristics. In order to have a good current supply the unit should have high impedance and should be able to produce rapidly changing voltages to meet a change in load values.

The PAE Series from Kikusui has a mode selector installed to satisfy both requirements. "Normal" mode is used when the unit is used as a constant voltage power supply unit with low noise and low ripple. While the "Fast" mode is used when the unit is

333859

used as a constant current power supply unit or when it is necessary to change the output voltage rapidly.

2) Meter Switch (21)

Turn on this switch when the unit is used while varying output values for a long-time period. The meters (indicators) are disconnected from the circuit for protection.

3) Over Voltage Protection (OVP) Set Switch (22)

OVP circuit monitors output voltage to cut off the input switch (a breaker type switch) when output voltage exceeds the limit value. If this switch is pushed on, the current value of the voltage limit will be indicated on the voltage meter, and if necessary, the value may be changed or adjusted by the rheostat installed below this switch.

Crowbar type thyristor OVP is available as an option for sharply lowering the output voltage on a load which is vulnerable to over-voltage, such as semiconductors. See details in SECTION 6. Options.

4) C/V Limit Switch (23)

By pushing down this switch, limit values of output voltage and current which are relatively represented to the internal reference voltage will be indicated on the voltmeter and ammeter, respectively. The values may be read during operation without any influence on output.

On the other hand, with the use of the output switch (24) in parallel to this switch, it is possible to preset a constant voltage value and constant current value.

5) Output Switch (24)

This switch turns the reference voltage on and off for constant voltage. In the "Off" state, the output voltage is limited to 0.1 volt or less. In the "On" state, the output LED (14) (orange) will be lit.

933863

3. Meter Sensitivity and Offset Adjustment

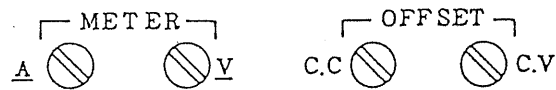

FIG. 2-5

1) Adjustment of Meter Sensitivity

PAE 35-30 uses meters of JIS Class 1.5, with which 5% error in indication is expected when used in the temperature range between 0° and 40°C.

Proper adjustment should be made depending on ambient temperature. When shipped, the meters are adjusted for 20°C.

NOTE: Japanese Industrial Standard (JIS) stipulates tolerance by grade based on difference between the indicated value at 20°C and value indicated when the surrounding temperature is varied by 10°C.

2) Offset Adjustment

Rheostats (17) and (18) provide for zero adjustment when remotely controlling the output. See details in SECTION 4., 2. and 3.

If a positive offset exists with the constant voltage knob (6) and constant current knob (7), there should be no point in giving zero volt and zero ampere on each dial even if they are turned counterclockwise to the extreme position. But for normal use, it is not necessary to correct such offsets.

4. Remote/Local Switch (on rear panel)

In remote programming mode, this switch is used in combination with the back panel terminals. For normal use, the position of this switch does not make any difference whether "remote" or "local." However, note that if this switch is switched during operation, output voltage will be lowered for an instant.

833861

SECTION 3. OPERATING PRINCIPLES

3-1. Operating Principles

1. Constant Voltage Operation

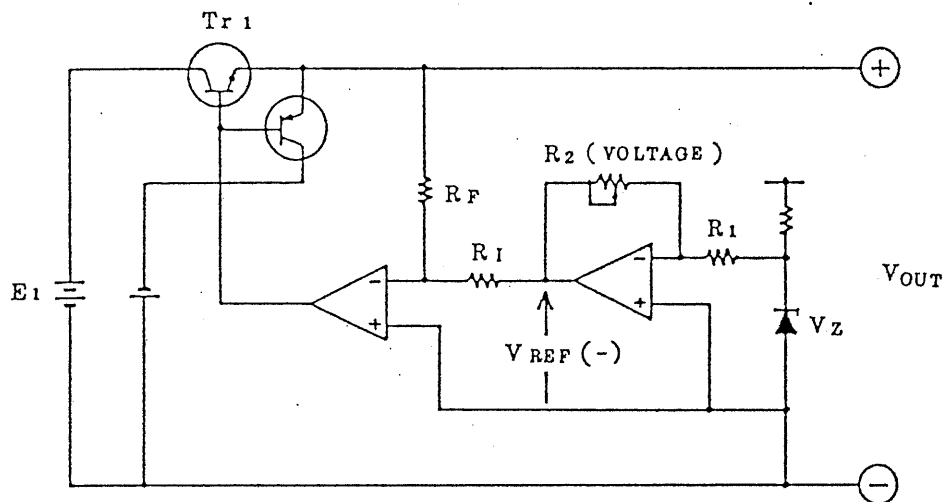

FIG. 3-1

The reference voltage V_{ref} changes in negative polarity proportionally to R_2 (VOLTAGE), as shown in the following relation:

$$V_{ref} = - \frac{R_2}{R_1} \cdot V_z \text{ (Volt)} \quad (3-1)$$

Output voltage V_{out} changes depending on V_{ref} according to the following relation:

$$V_{out} = - \frac{R_f}{R_i} \cdot V_{ref} \quad (3-2)$$

$$= \frac{R_2 \cdot R_f \cdot V_z}{R_1 \cdot R_i} \text{ (Volt)} \quad (3-3)$$

The complimentary connection, employed in the last stage of the constant voltage circuit, causes the output voltage to fall sharply. Also, the output voltage from E_1 , which is actually output from the main rectifier circuit, is designed to be able to take four discrete values for decreasing the collector loss of Tr_1 .

2. Constant Current Operation

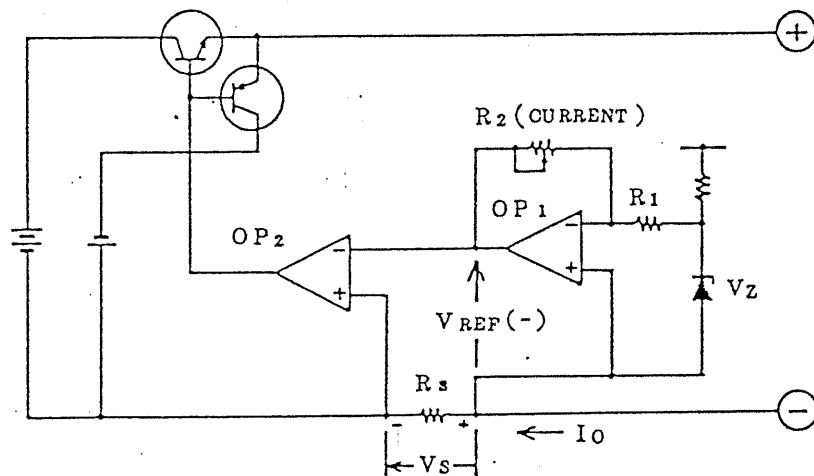

FIG. 3-2

The negative reference voltage V_{ref} changes in negative polarity proportionally to R_2 (CURRENT), as shown in the following relation:

$$V_{ref} = - \frac{R_2}{R_1} \cdot V_z \quad (3-4)$$

The output current I produces negative voltage V_s over the current sensing resistance R_s , making V_s equal to V_{ref} according to the following relations:

$$V_s = V_{ref} \quad (3-5)$$

$$- I_o \cdot R_s = - \frac{R_2}{R_1} \cdot V_z \quad (3-6)$$

$$I_o = \frac{R_2 \cdot V_z}{R_s \cdot R_1} \quad (\text{Ampere}) \quad (3-7)$$

3-2. Protection Circuits

Overvoltage protection: The power supply switch will be cut off when OVP state is created,

Overcurrent protection: A current limit circuit with the maximum current value of 33 amperes is installed, it is designed so that the secondary

833863

fuse will open when overcurrent runs
for a long time.

Temperature protection: The power supply switch will be cut
off at 100°C by the action of the
heat block.

833888

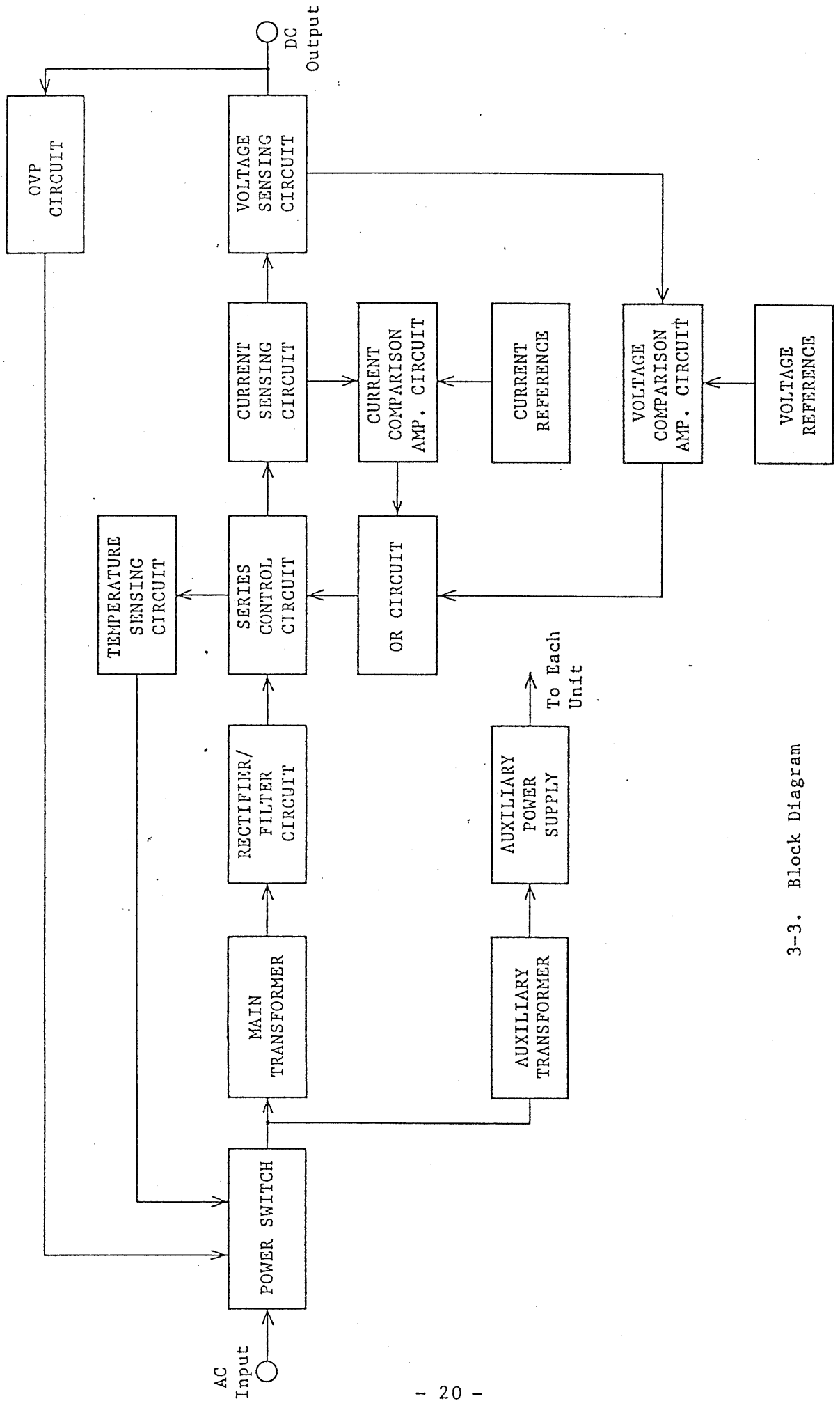

3-3. Block Diagram

SECTION 4. APPLICATIONS

4-1. Remote Sensing

In order to prevent voltage drop caused by wire cable resistance and lowering of operation stability due to contact resistance, it is necessary to set the voltage sensing points as close to the ends of the load as possible.

The procedures for doing this are as follows:

1. Turn off the power switch.
2. Remove the jumpers installed at the terminal board on the rear panel to connect +S and + and to connect -S and -.
3. Connect +S and -S to the places where stabilization is desired. (Use twisted pair shielded cable line to avoid bad influence on ripple voltage caused by inducing.) Shield cover shell should be connected to the - terminal.

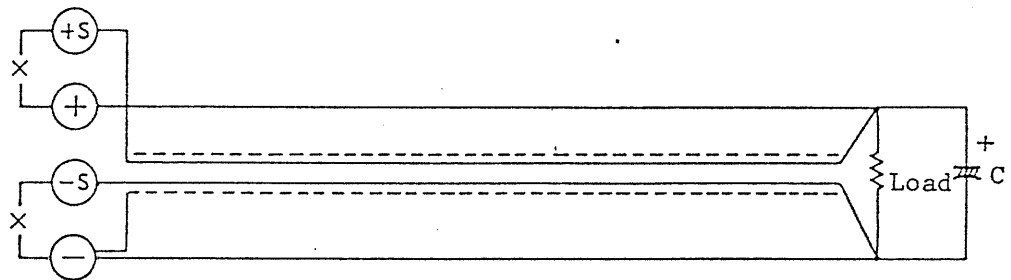

FIG. 4-1

NOTE 1: Maximum voltage drop to be compensated for by this unit is approximately 1 volt.

NOTE 2: Be aware that there is no sensing effect for frequency ranges exceeding 1 kHz.

NOTE 3: Use shielded line cable with relatively large diameter. Otherwise, good load varying characteristics may not be expected.

833866

NOTE 4: In case $\frac{di}{dt}$ is large in value due to rapidly changing load current, the voltage $L\frac{di}{dt}$ due to the inductance L of the load lead cable will become a factor, therefore voltage stability at the end of load may be worsened. Such situations may be avoided by connecting thousands to tens of thousands μF electrolyte condensers to both ends of the load in the shortest distance.

4-2. Remote Programming of the Output Voltage

By this method, the output voltage may be controlled by means of an external resistance or external voltage.

Precaution:

Whenever rapidly changing the output voltage, be sure to set the instrument in the "FAST" mode. If it is in the "NORMAL" mode, the output voltage cannot follow the input signal and, if the instrument remains in this situation for a prolonged time, the output capacitor may be damaged.

1. Output Voltage Control with an External Resistance

Step 1. Turn off the power switch.

Step 2. Remove the jumper connecting terminals 1 and 2 on the back panel.

Step 3. Connect resistor R_1 between terminals 1 and 3, and turn on the power switch.

Step 4. Adjust the C.V. offset on the front panel so that the output voltage will become zero when the value of R_1 is zero.

$$\text{Output voltage } E_o = 3.6 R_1 \text{ (Volt)} \quad (4-1)$$

where $R_1 < 10 \text{ (K}\Omega\text{)}$

833847

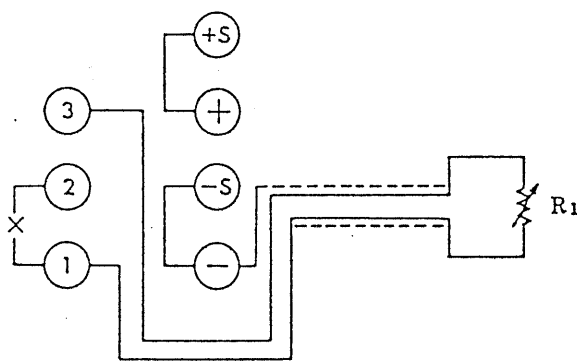

FIG. 4-2

NOTE 1: Use twisted pair seal line for R_1 connection, and connect the shield shell to the (-) minus terminal.

NOTE 2: About 1 mA of current will flow through R_1 regardless of its resistance value, when programming on voltage is not made.

NOTE 3: Use a resistor with a good temperature coefficient for R_1 .

NOTE 4: If a type of resistance is used whose value may be varied by a switch, it should be either closed circuit type or continuous type which has a mechanism to be able to keep the circuit closed even when the resistance value is switched to change. Otherwise, overvoltage is caused.

2. Output Voltage Control with an External Voltage

Step 1. Turn off the power switch.

Step 2. Set the remote/local switch to "Remote" position.

Step 3. Remove the jumper connecting terminals 4 and 5 on the back panel.

- Step 4. Short circuit terminals 4 and -S, and turn on the power switch, and set the output voltage to zero volts using the C.V. offset located on the front panel. When doing this, the constant voltage dial should have been turned clockwise to the extreme end.
- Step 5. Apply voltage between terminals -S and 4 in the right polarity. The ratio of voltage to input voltage may be controlled by the use of the constant voltage dial.

$$\text{Output voltage } E_o = 0.4 E_i \cdot R_v \quad (4-2)$$

R_v : Resistance value set by the constant voltage dial (k Ω , maximum value 10 k Ω).

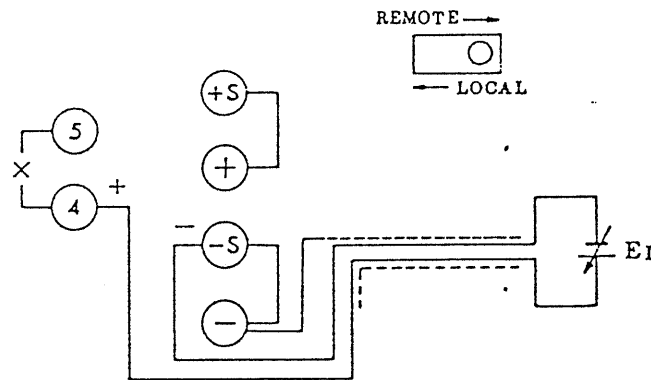

FIG. 4-3

Example 1: Programming to get 35 volts output to 10 volts input.

After following steps 1 through 3 listed above, turn the constant voltage dial counterclockwise to the extreme position. Then, after setting E_i to 10 volts, turn the constant voltage dial clockwise slowly to set the output voltage to 35 volts.

Example 2: Programming to get 35 volts output to 1 volt input

Applying $E_i = 1.0$ and $E_o = 35$ to equation (4-2) gives $R_v = 88 \text{ k}\Omega$. Therefore it is impossible to

0000000000

get 35 volts output from the resistance values within the range of the constant voltage dial. Therefore, other external resistances with higher values have to be added. In order to accomplish this, programming controlled by an external resistance, should be used. Namely, after removing the jumper connecting terminals 1 and 2, connect an 88 k Ω resistor between terminals 1 and 3. Note: In all cases, this resistance must be 100 k Ω or less.

NOTE 1: When performing a programming operation, care should be taken so that maximum ratings of the power supply unit will not be exceeded.

NOTE 2: Use twisted pair shielded cable for the input signal line, and connect the outer shield shell to the (-) minus terminal.

NOTE 3: Use the attached guard cap on the top of the constant voltage dial for safety purposes. This can avoid the dials being moved by an unintentional slight touch.

NOTE 4: The value of the input resistance between -S and 4 is approximately 9 k Ω .

NOTE 5: If the remote/local switch is set to "Local," the internal reference voltage (9.1 volts) will be used as the input voltage E_i .

4-3. Remote Programming to Control the Current Output

By this method, output current may be controlled by external resistance or external voltage.

Precaution:

Whenever rapidly changing the output current, be sure to set the instrument in the "FAST" mode. If it is set in the "NORMAL" mode, the output current may not change rapidly due to the filtering effect of the output capacitor. If the load is

inductive, transient voltages generated when the current is sharply reduced may cause the OVP circuit to trip.

1. Output Current Control with an External Resistance

- Step 1. Turn off the power switch.
- Step 2. Detach the jumper connecting terminals 8 and 9 on the back panel.
- Step 3. Connect resistor R_2 between terminals 8 and 10, and turn on the power switch.
- Step 4. Attach a load to R_2 and adjust the C.C. offset on the front panel so that the output current will become zero when $R_2 = 0$.

$$\text{Output current } I_o = 30 R_2 \text{ (Volts)}$$

where, $R_2 < 1.0 \text{ (k}\Omega\text{)}$.

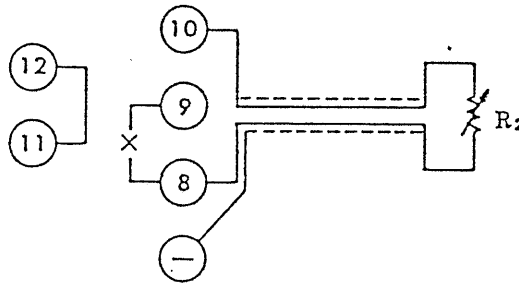

FIG. 4-4

- NOTE 1: Use twisted pair shielded cable for connecting R_2 . The shield shell should be connected to the (-) minus terminal.
- NOTE 2: Approximately 0.5 mA of current will flow through R_2 regardless of its resistance value, as long as programming by voltage is not in use.
- NOTE 3: Use a resistor with a good temperature coefficient for R_2 .

833871

NOTE 4: If the resistor used is the type whose value may be changed by use of a switch, it should be either a closed circuit type or a continuous type which has a mechanism to be able to keep the circuit closed even when the resistance value is switched. Otherwise, overvoltage is caused.

NOTE 5: Operation exceeding the maximum ratings must be avoided.

2. Output Current Control with an External Voltage

Step 1. Turn off the power switch.

Step 2. Set the remote/local switch to "Remote" position.

Step 3. Detach the jumper connecting terminals 11 and 12 on the back panel.

Step 4. Turn on the power switch and attach a load.

Step 5. While short circuiting terminals J and 11, adjust the C.C. offset on the front panel so that the output current will become zero. In this case, the constant current dial must be turned fully clockwise to the extreme position.

Step 6. Apply a voltage between terminals J and 11 after making certain that polarity is correct. The ratio of output current to input voltage may be controlled with the constant current dial.

$$\text{Output current } I_o = 3.3 \times R_c \times E_i \text{ (Volt)} \quad (4-3)$$

where, R_c = Resistance value set by the constant current dial (0 - 1 k Ω (max.)).

833079

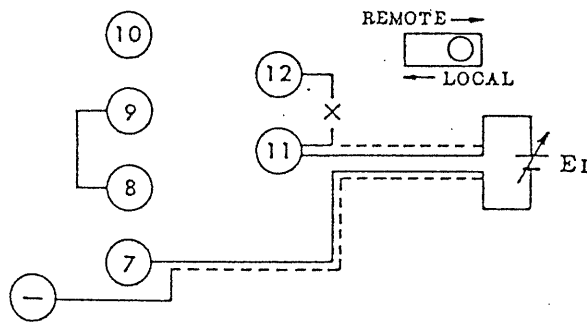

FIG. 4-5

Example 1: To Get 30A Output Current to 10 Volts Input

After following Steps 1 through 4 described above, slowly turn the constant voltage dial clockwise to get an output current of 30 amperes.

Example 2: To Get 30A Output Current to 1.0 Volt Input

Applying $E_i = 1.0$ and $I_o = 30.0$ to equation (4-3), a result of $R_c = 9.1$ is obtained. Therefore, an additional external resistance has to be attached to satisfy this case. To accomplish this, the programming for control by an external resistance shall be used, that is, after the jumper connecting terminals 8 and 9 is detached, connect a $9.1 \text{ k}\Omega$ resistor between terminals 8 and 10. Note: The value of this resistance must not exceed $100 \text{ k}\Omega$.

NOTE 1: Take care in programming so that the maximum ratings of the power supply unit are not exceeded.

NOTE 2: Use twisted pair shielded cable for the input signal line, and also be certain that the shield shell is connected to the "-" terminal.

NOTE 3: By using the attached guard cap over the constant current dial, unintentional movement of the dial may be avoided.

833873

NOTE 4: The value of the input resistance between terminals 7 and 11 is 18 k Ω .

NOTE 5: If the remote/local switch is set at "Local," the internal reference voltage (9.1 volts) will be used as the input voltage E_i .

4-4. On/Off Control of the Output by an External Terminal

1. Short circuit terminals 1 and 3 on the back panel. The output voltage will become approximately zero. This method is used to make the reference voltage a constant voltage zero, and the voltage meter will indicate zero if the C/V limit switch is depressed.
2. Short circuit terminals 8 and 10. The output current will become approximately zero. This method is to make the reference voltage to constant current zero, and if the C/V limit switch is depressed, the ammeter will indicate zero. Although, when no load is mounted, a certain amount of voltage may be created, depending on the state of the C.C. offset.

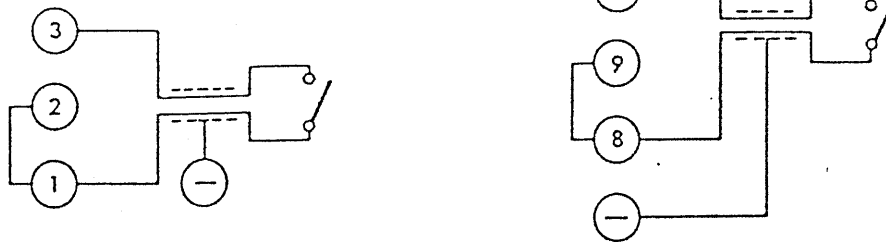

FIG. 4-6

NOTE 1: Use twisted pair shielded cable for connecting the switches.

NOTE 2: When no voltage control is applied on the switches, currents of approximately 1.0 mA and 0.5 mA will be created for case 1 and case 2, respectively.

833874

4-5. Master/Slave Operation

To attain a larger supply current, two (or more) power supply units of the same model can be connected in parallel and operated in a master/slave mode. The master/slave mode is such that one of the units is operated as a master unit and the remaining unit(s) is operated as a slave unit(s). The master unit dictates operation of all units and the slave unit(s) operate being dictated by the master unit.

Model PAE35-30 Power Supply Units are of a high speed output response type. Therefore, whenever operating them in parallel, operate them in the master/slave mode.

It is unrecommendable to operate them in the conventional parallel mode. If you operate them in the conventional parallel mode, the unit(s) of lower output voltage(s) will absorb the output current(s) of the unit(s) of higher output voltage(s), resulting in increase of internal loss and blowing out of internal fuse(s) in an extreme case.

For the master/slave mode of operation, proceed as follows (assuming that only one slave unit is used):

- Step 1. Turn off the POWER switches of the units. (Be sure to turn off the input power switches of the units before starting setting-up the units for master/slave operation.)
- Step 2. Place the master unit and slave unit at a close distance. (Do not locate them mutually apart.)
- Step 3. Disconnect the jumper from between rear terminals (8) and (9) of the slave unit. (See the illustration below.)
- Step 4. Short between rear terminals (7) and (10) of the slave unit.
- Step 5. Turn the OFFSET C.C dial of the slave unit to the full clockwise position.
- Step 6. Connect rear terminal (6) of the master unit to rear terminal (8) of the slave unit.

197.04/8

833875-1B

Step 7. Connect in parallel the output terminals of the master and slave units as shown in the below illustration.

NOTE: When branching the "-" line for connection to the "-" terminals of the master and slave units, the lengths (l_1 and l_2 indicated in the below illustration) must be as short as possible (must not be longer than 30 cm) and must be of the same lengths. Note that, if the lengths differ, the output currents of the units will become unbalanced.

Step 8. Turn the voltage setting dial of the slave unit to the full clockwise position.

Step 9. Turn on the OUTPUT switch of the slave unit.

Connections for
Master/Slave
Setup

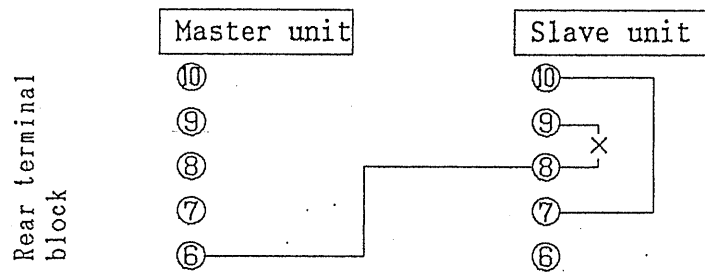

Binding posts
on front
panels

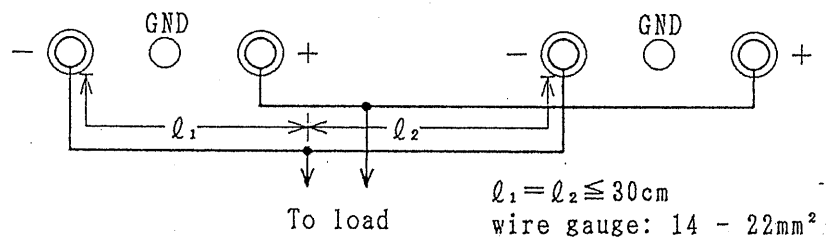

Start-up/Shut-down Sequence

To start up or shut down the power supply system, be sure to observe the following sequence.

Start up: At first, be sure that the OUTPUT switch of the master unit is off. Next, turn on the master unit and then slave unit. Then, turn on the OUTPUT switch of the master unit.

Shut Down: At first, turn off the OUTPUT switch of the master unit. Next, turn off the master unit and then the slave unit.

129 04 18

833875-2B

NOTE 1: During in parallel operation, the C.C lamp (red) of the slave unit illuminates.

NOTE 2: Remote sensing operation and remote control operation must be done only with the master unit.

NOTE 3: The ripple, noise, and rise up characteristics of the units operated in parallel may compare unfavorably with those of units operated mutually independently.

NOTE 4: Note that the parallel operation may be unsuitable depending on the type of load and the ratings of wiring lines and other factors and operation of the units may become unstable. For details, please consult your Kikusui agent.

4-6. Series Operation

Series connection of voltage outputs from a number of units gives a total output range equal to the voltage summations. Explained in the following is the master/slave method to control total series output voltage only through the operation of the master unit. Incidentally, the power switch of every unit which takes part in a series operation must be turned on. If there is a unit whose power switch is not turned on, the output current is forced to run through the diode installed in parallel to the output terminals, for preventing breakage in case of a reverse connection, therefore that the diode will overheat and be damaged.

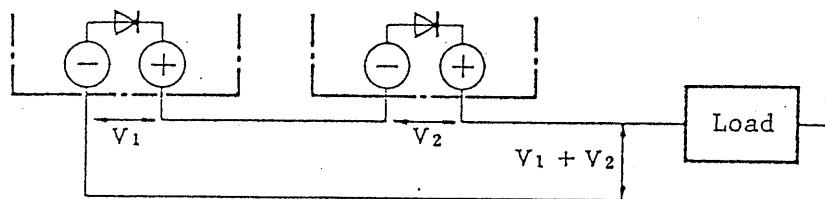

FIG. 4-8

Step 1. Turn off every power switch.

1890418

833876B

Step 2. Connect the + terminal of the master unit (to control the output) and the - terminal of the slave unit(s) (to be controlled by the master unit). The electric potential of the slave unit will become higher than that of the master.

Step 3. Detach the jumper connecting terminals 1 and 2 of the slave unit(s).

Step 4. When the operation of the master/slave method, put off the back cover 1 of all slave units, and throw switch S3 to upper position on PC board.

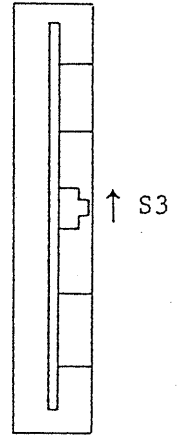

Step 5. Connect terminal -S of the master unit and terminal 1 of the slave unit, with a 91 kΩ resistance.

Step 6. Connect the GND terminals of each unit together, and ground only the output terminal of the unit which has the lowest potential or the highest potential depending on whether the case is negative ground or positive ground.

FIG. 4-9

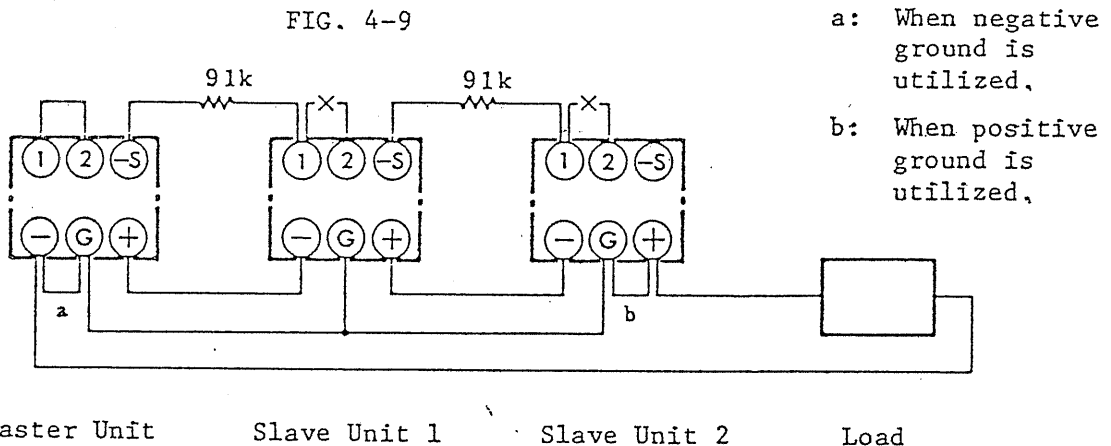

NOTE 1: Maximum output voltage for serial operation should not exceed the voltage to the ground ($\pm 250V$ DC).

NOTE 2: Turn the constant current dial of the slave unit clockwise and set it at the maximum position.

833877

NOTE 3: Use a 91 k Ω resistor with a good temperature coefficient.

NOTE 4: For performing remote sensing, use terminals +S at the highest level and -S at the lowest level.

NOTE 5: The ripple characteristics may worsen in this operational mode.

4-7. Battery Charging

Battery charging should be made in the Normal mode.

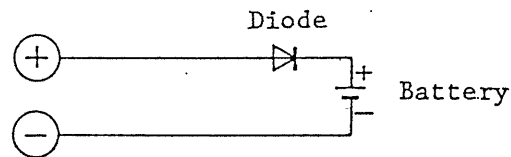

FIG. 4-10

After depressing the C/V limit switch, set the charging completion voltage and the charging current by the constant voltage dial and the constant current set dial, respectively, so that the constant rate current charge may be performed accordingly and stopped automatically.

NOTE 1: Check overheating by observing the diode's heat discharge.

NOTE 2: The diode may be omitted if the following method is taken: set a switch between the battery and the output terminal and turn on the switch after the output voltage is set at a value slightly higher than the battery voltage.

NOTE 3: After the completion of charging, turn off the switch and then turn off the power switch.

NOTE 4: If the output voltage of the power source is lower than that of the battery or if the switch of the power is turned off before the battery switch is turned off,

0333878

the power source will absorb the current.
Lengthy repetition of this may damage the power
unit.

4-8. Cut Off of Power Supply Switch by External Terminals

Short circuiting terminals 13 and -S on the back panel will cut off the power switch (circuit breaker) in an instant.

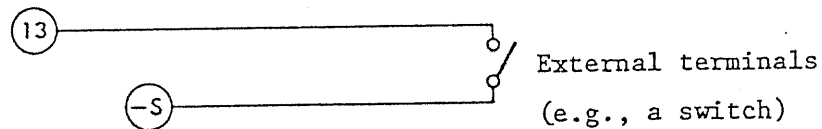

FIG. 4-11

NOTE: Maximum instantaneous current through a switch is 100 mA with 12 V.

4-9. Use of Card Edge Terminals

The card edge with 22 terminals in 4 mm pitch may be used by removing cover #1 on the back panel. The following product is recommended for use: KEL 3205-022-011 manufactured by KEL, Inc. The connection of each terminal of the card edge is as follows:

833879

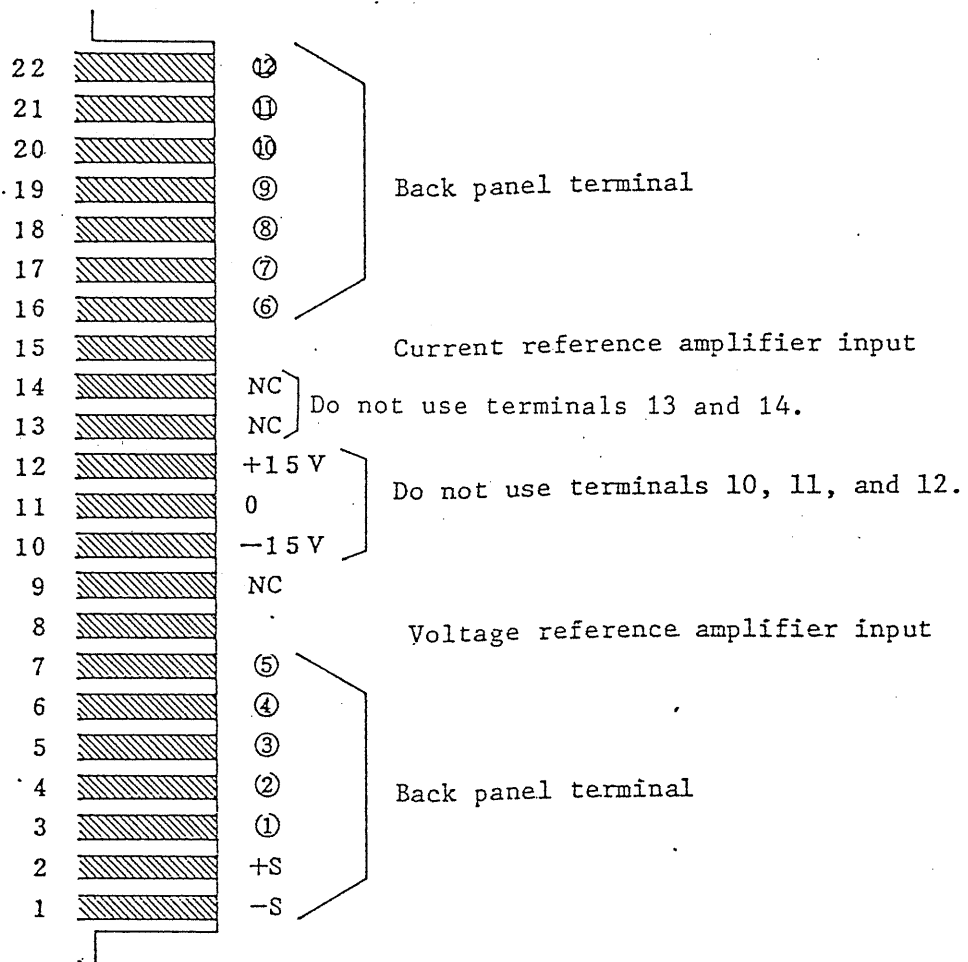
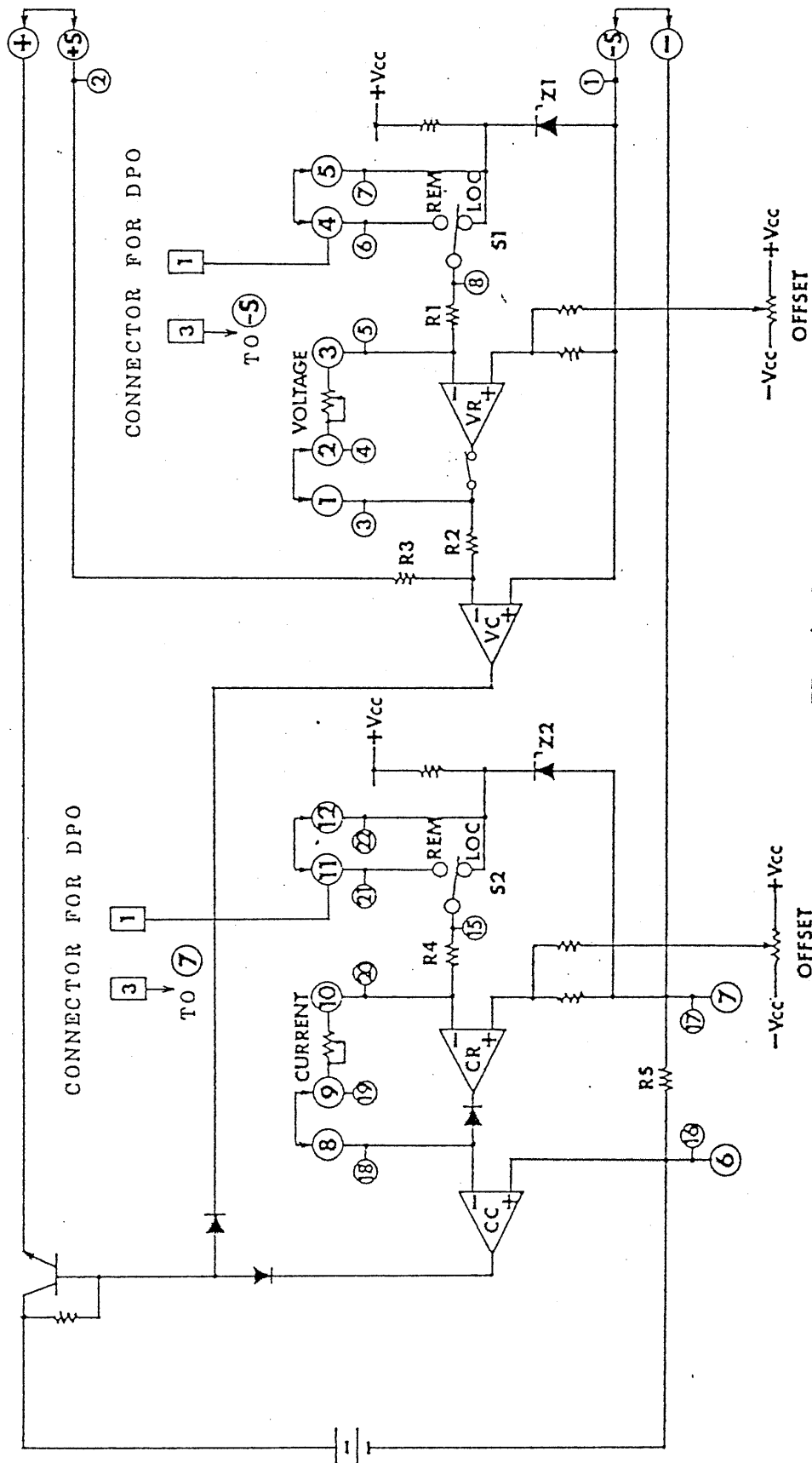

FIG. 4-12

833888



4-10. Diagram of Back Panel Terminals

Z1 Voltage reference diode (9V)
 S1 Remote/Local switch (9 kΩ)
 R1 Voltage reference amplifier (10 turns 10 kΩ)
 VR Voltage (35 kΩ)
 R2 Constant voltage amplifier (126 kΩ)
 VC

Z2 Current reference diode (9V)
 S2 Remote/Local switch (15 kΩ)
 R4 Current reference amplifier (10 turns 1 kΩ)
 CR Current sensing resistance (35 kΩ)
 RS Constant current amplifier (126 kΩ)
 CC

FIG. 4-12

NOTE 1: S1 and S2 are interlocked.

NOTE 2: A small circled number represents a card edge.

SECTION 5. MAINTENANCE

- 5-1. Keep routine inspections and adjustments without fail so that initial performances may be maintained for long periods of time.

1. Cleaning

In cleaning the panel surface, wipe the surface with a cloth containing diluted neutral detergent or alcohol, and then rewipe with a dry cloth. Blow off the dust accumulated inside the case and the air-hole openings by using a compressor or vacuum cleaner.

2. Check of Power Supply Cable

Check for breakage of the vinyl cover layer of the cable line, and cracking and ricketiness of the plug socket.

3. Adjustment of Voltmeter

After setting the output voltage at the maximum value, measure the voltage between terminals +S and -S with a voltage meter having precision of 0.5% or higher, and adjust the voltage meter by the voltage meter adjuster V on the front panel such that the reading is the same as the measured value.

4. Adjustment of Ammeter

After connecting an ammeter with 0.5% precision to the output terminals and setting the current at the maximum value, adjust the ammeter by the ammeter adjustment A on the front panel so that the reading is the same as the measured value.

5-2. Symptoms and Causes of Operation Failures

1. When trouble occurs, check the following points first:

- Check if the jumper connections on the back panel terminals are correct and the screws that fasten them are tight.

833883

- . Check the back panel terminals in use for problems like miswiring, miscalculations and/or excessive input.
- . Check to see if the value set on the overvoltage protection circuit is too low.
- . Check if the power supply voltage is normal (appropriate).

2. Check Points and Causes of the Symptom

After checking/correcting the above points and the problem still remains, refer to the following:

Symptom #1: No output at all (neither the fan works nor lamps are lit).

Cause A: Fuse of the input line is burnt out.

Remedy A: Change the fuse and look for the cause.

Cause B: No voltage is supplied to the input terminal of the line because the supply cable is damaged.

Remedy B: Change the cable.

Symptom #2: No output at all, but the fan works.

Cause: The fuse on the secondary side is blown.

Remedy: Replace the fuse and find the cause of the blown fuse.

Symptom #3: Power supply switch does not work.

Cause A: OVP is working.

Remedy A: Recheck the back panel terminals.

Cause B: Overheat protection circuit is working because of operating in an environment with high ambient temperature.

Remedy B: After cooling the room temperature, turn on the power supply switch again.

Symptom #4: Power supply switch is cut off.

Cause: Counter electromotive force due to turning on and off of an inductive load at high rate has caused OVP work.

Symptom #5: Unstable output and/or large ripple voltage.

Cause A: An oscillation is caused.

Remedy A: See Chapter 2, 2-1.6

Cause B: Disturbing magnetic and/or electric field from an external source. Check if there is noise in the power line caused by regulation.

Remedy B: Remove the noise source from around the unit.

NOTE: If any of the above items are not helpful in solving the problem, it is very likely that the unit has circuit problems. In such case, contact Kikusui Internal or its branch offices. Repair work will be done by Kikusui or certified authorized service agents.

8338884

SECTION 6. OPTIONS

6-1. Standard Racks and Installation

Kikusui manufactures not only a standard size rack in the EIA standard but also racks in the NTT standard, to accommodate the Kikusui units. See details in the related catalogues. Incidentally, it is necessary to replace the rubber feet of the unit by the specially prepared brackets with size in millimeter or inch, depending on the size standard employed, NTT standard or EIA standard, respectively. Also, if more than one unit is integrated on to a rack, give at least one panel width (44 mm) space between each unit, for good ventilation.

6-2. Installation of DPO

Digital Programming Option (DPO) unit which consists of an interface and a digital/analogue converter are used for controlling output of a power supply unit through a computer bus, such as GP-IB and an I/O port. The DPO may be installed within the PAE 35-30 power supply unit very simply with screws and connector. On the other hand, by use of the remote/local switch installed on the back panel of the unit, the state without DPO option will be available very easily without removing the option unit.

A reference booklet Installation of DPO Unit on to PAE Series is available from Kikusui International or its branch offices in the US upon request. See the catalogue of DPO for detailed specifications on DPO.

6-3. Crowbar

The Over Voltage Protection Circuit (OVP) which is built in the PAE 35-30 unit will turn off the power supply switch when overvoltage state is sensed. However, in case of a load which is vulnerable against overvoltage, such as a semiconductor, the response speed is usually unsatisfactory. To overcome this

833885

problem, a thyristor should be installed in parallel to the output load to cut off output voltage instantly so that the output will be short circuited as soon as the trigger signal is sensed. This thyristor must be fixed by soldering. The soldering work will be performed only by Kikusui.

SECTION 7. INSTALLING THE DPO

The DPO (digital control devices for D/A converters, interfaces, etc.) can be installed in the main unit of the PAE Power Supply.

(1) Option A and Option B

With Option A, either the output voltage or current can be controlled. With Option B, both output voltage and current can be controlled. (As a general rule, both voltage and current can be controlled only in the case of GP-IB control.)

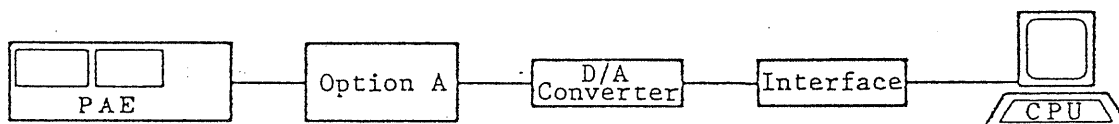

FIG. 1 To control either voltage or current

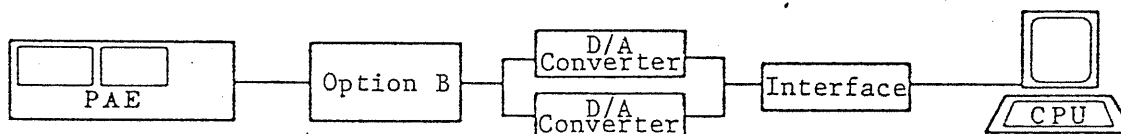

FIG. 2 To control both boltage and current
(GP-IB only)

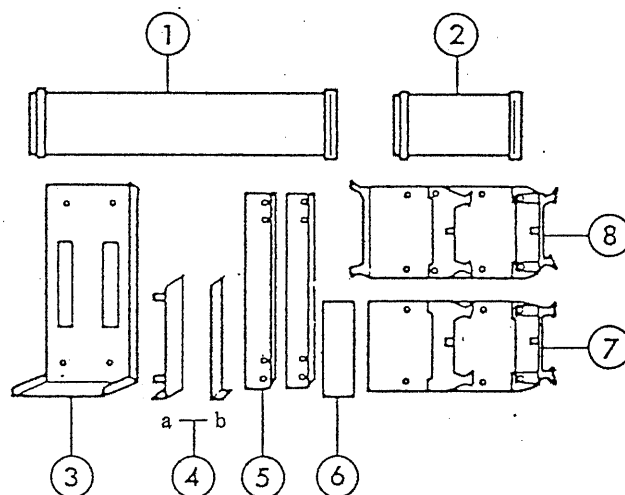

FIG. 3

(2) Contents of set of Option A or Option B

	<u>Q'ty</u>		<u>Q'ty</u>
① 20CM flat cable	1	⑨ Screws, steel M3 × 6	2
② 10CM flat cable (B only)	1	Screws, steel M3 × 8	6
③ D/A bracket	1	Screws, brass M3 × 6	4
④ I/F bracket a,b	1	Screws, brass M2.6 × 6	2
⑤ I/F angles	2	Springs M3	4
⑥ Cover	1	Springs M2,6	2
⑦ Connector board A (A only)	1	Washer, plain M3	8
⑧ Connector board B (B only)	1	Nuts M3	4
		Bands	2

(3) Notes for installing the DOP

*: Use a D/A converter of which output voltage is not greater than 10V, for either voltage or current control. To control with GP-IB, use a device of which listener format is K□□□V for voltage control or K□□□A for current control.

00000000

*: For the PAE Power Supply, a single unit of interface device is used for both voltage and current control. Therefore, when the D/A converter and the interface device are mutually remotely installed (when an expansion unit is used), the length of the cable must not be longer than 25 meters.

(4) Installation method of DPO

Prepare the following tools:

- o Screwdriver, Plain, for M3 screws
- o Screwdriver, Philips, for M2.6 screws
- o Wrench, box or adjustable, for M3 screws

- 1) Fix connector board A (7) or B (8) to I/F bracket (4). (See Figure 4.)
- 2) Fix the D/A converter to D/A bracket (3). (See Figure 5)

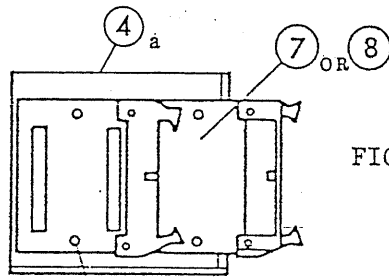

FIG. 4

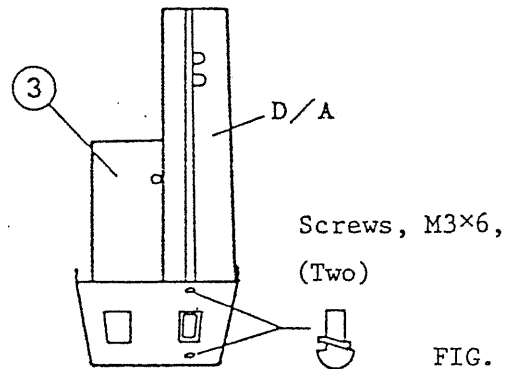

FIG. 5

- Washers, plain, M3
- Washers, spring, M3
- Nuts, M3
- (Four)

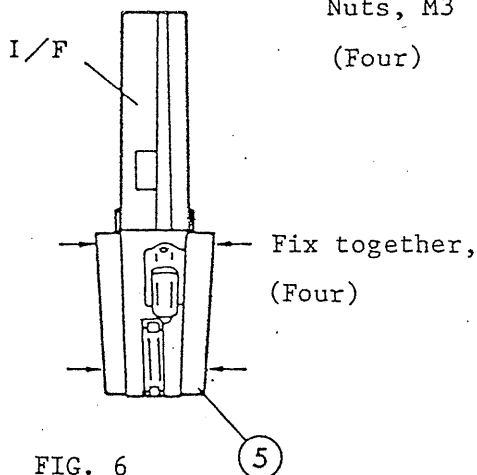

FIG. 6

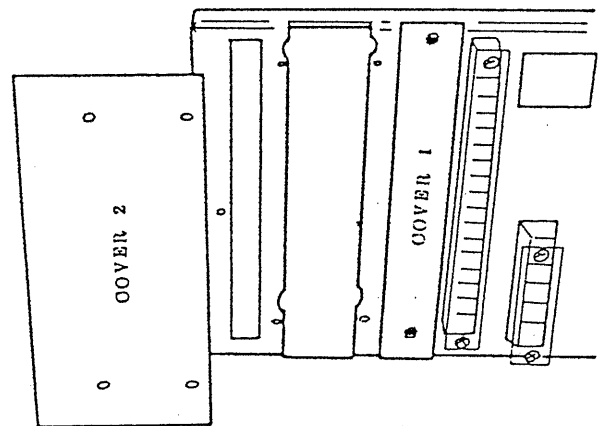

FIG. 7

6883889

- 3) Fix I/F angle ⑤ to the interface. (See Figure 6)
- 4) Disconnect the power cord from the receptacle of main unit of PAE. Remove rear cover 2. (See Figure 7)
- 5) Insert the connector of main unit of PAE in the D/A converter. (See Figure 8.) There are two connectors. Identify them by their colors. (See Table 1.)

Table 1. Color coding of terminal 1 of connector

	Connector of voltage side	Connector of current side
PAE 35-10	Orange	Blue
PAE 35-20	Red	Red/white
PAE 35-30		

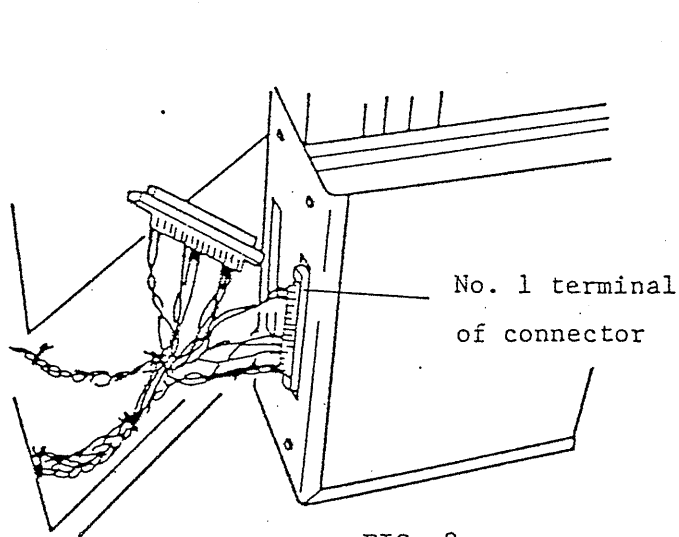

FIG. 8

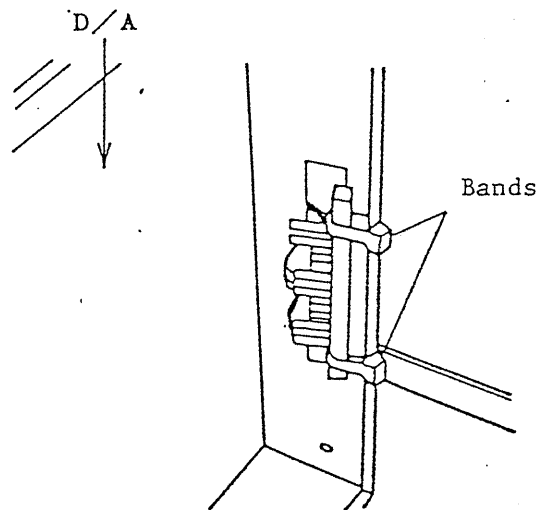

FIG. 9

- 6) Bind the unused connector with bands as shown in Figure 9.
- 7) Fix the bracket (to which the D/A converter is fixed) to the PAE with the screws from its bottom. (See Figure 10)
- 8) Fix the bracket (to which the connector board is fixed) to the PAE with the screws from its bottom. (See Figure 10)

833890

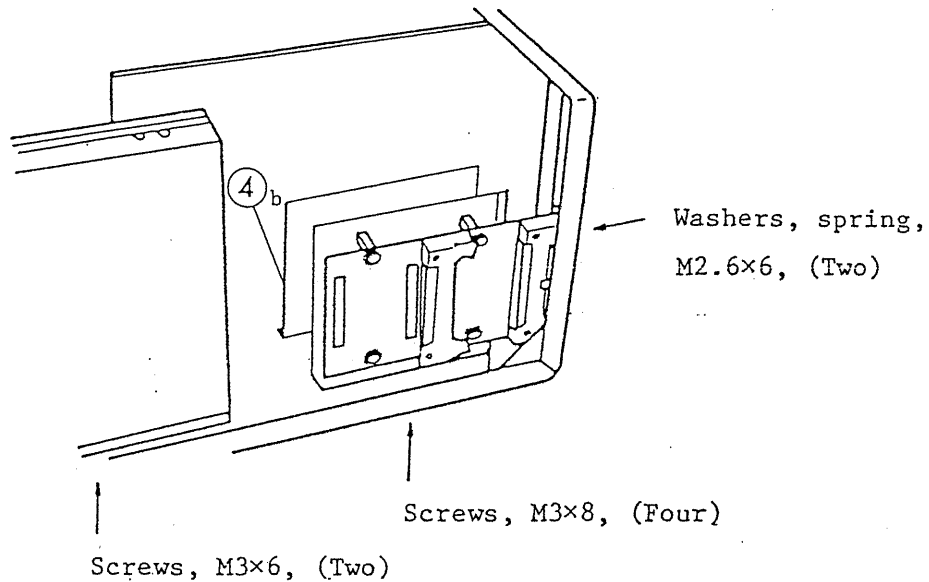

FIG. 10

- 9) Insert the interface (to which the I/F angle is fixed) in the PAE from its rear. Connect the interface to the connector board with the 10CM flat cable (which accompanies the I/F). (See Figure 11.)
- 10) Connect the connector board to the D/A converter with the 20CM flat cable. (See Figure 12.)
- 11) To control both voltage and current, make connections as shown in Figure 13.
- 12) Fix cover (6).
- 13) To control voltage, disconnect the shorting bar from between rear terminals (4) and (5). To control current, disconnect the shorting bar from between rear terminals (11) and (12). To control both voltage and current, disconnect both shorting bars.
- 14) Throw the REMOTE/LOCAL selector switch of the D/A converter and that on the rear panel of the power supply to their REMOTE position.

833804

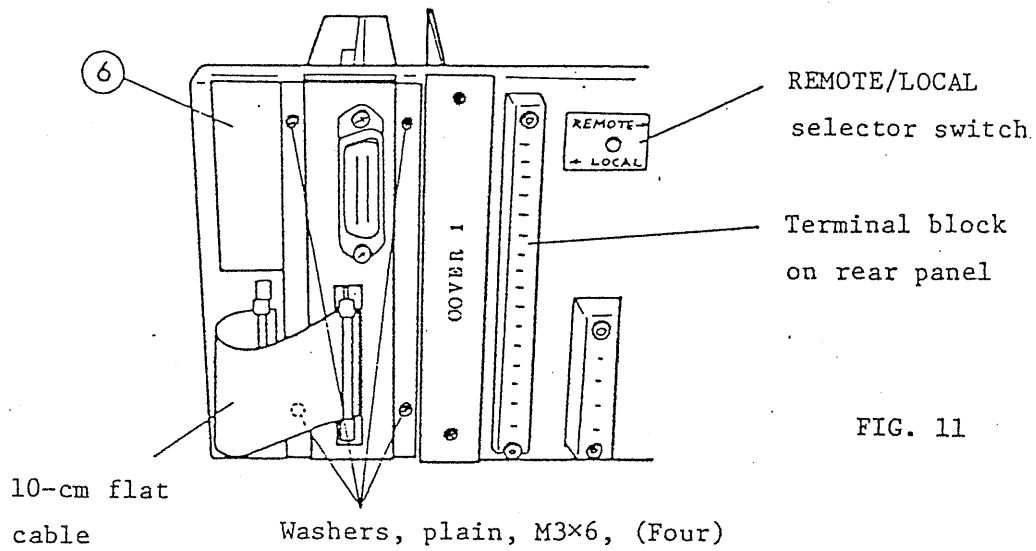

FIG. 11

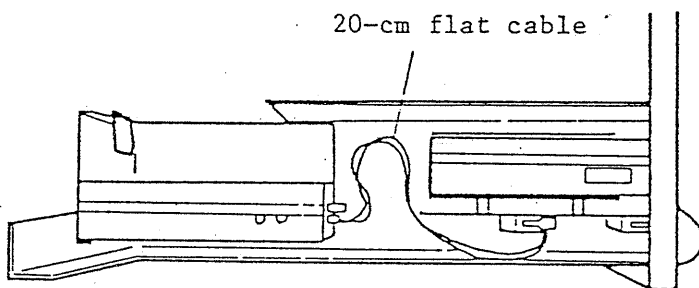

FIG. 12

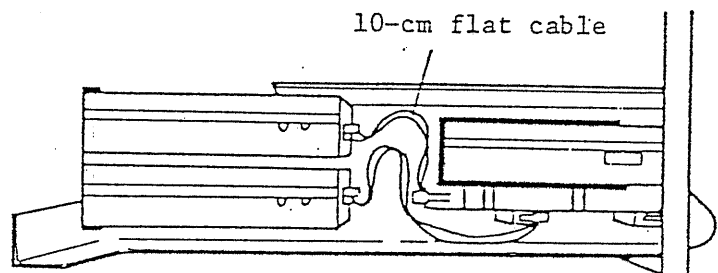

FIG. 13

(5) Adjusting Methods

Connect the digital bus to the interface and set the address for the interface.

1) To control voltage

1. Set the power supply in the no-load state. Turn the voltage and current knobs to the fully clockwise position. Turn on the power switch.
2. Send 0-volt output data (K000V)* to the control bus
3. Adjust the 0V (zero volts) control of the D/A converter so that the output voltage becomes zero volts. If the zero-volt level cannot be covered with the control alone, adjust also the C.V OFFSET control on the front panel of the power supply.
4. Next, send to the bus the data for the maximum output (K255V for the 8-bit system or K999V for the 12-bit system)* and adjust the FS control of D/A converter so that the power supply output becomes 36V.

*: Formats of GP-IB system

5. To guard the constant-voltage knob against inadvertent change which may cause undesirable change of the output voltage when the power supply is being controlled with DPO, it is recommended to protect the knob with the guard cap which accompanies the power supply.

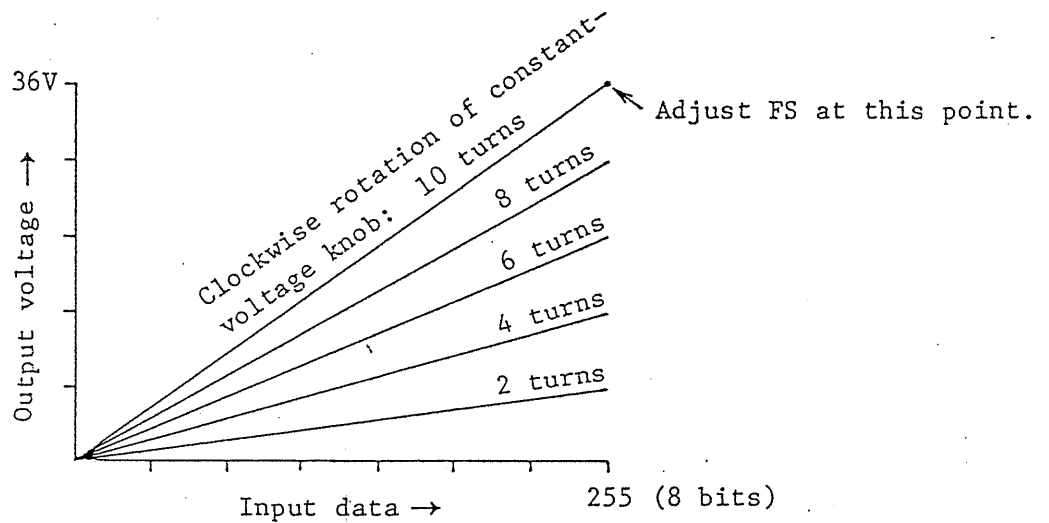

FIG. 14

6. To restore the original state (DPO is disconnected and the output voltage is controlled only with the constant-voltage knob), throw to the LOCAL position the REMOTE/LOCAL switch located on the rear panel of the power supply.
- 2) To control current
1. Short the output, turn the constant-voltage and constant-current knobs to the fully clockwise position, and turn on the power switch.
 2. Send 0-ampere output data (k000A)* to the control bus.
 3. Adjust the 0A (zero amperes) control of the D/A converter so that the output current becomes zero amperes. If the zero-ampere level cannot be covered with the control alone, adjust also the C.C OFFSET control on the front panel of the power supply.
 4. Next, send to the bus the data for the maximum output (K255A for the 8-bit system or K999A for the 12-bit system)* and adjust the FS control of D/A converter so that the output current of the power supply becomes the rated value.
- *: Formats of GP-IB system
- 3) To control both voltage and current (GP-IB only)
1. Set the power supply in the no-load state. Adjust 0V and FS as is the case of control of voltage. Set the output current at approximately 1 ampere (K025A)* so that the current limiting function is not brought into effect.
 2. Next, short the output. Adjust 0V and FS as is the case of control of current. Set the output voltage at approximately 5V (K035V)* so that the voltage limiting function is not brought into effect.

*: In the case of 8-bit system (At PAE 35-10)

8338001

4) Notes

1. When in FS adjustment, the OVP of the main unit of power supply may be brought into effect depending on setting of the FS control.
2. Be sure to restore the cover of the power supply back to the original state after adjustment is complete.
3. After the cover is closed, change of addresses can be made by pulling out the interface from the rear of the power supply.

(6) Others

To control the power supply with an external voltage signal after the DPO is installed, open the cover of the main unit and throw the REMOTE/LOCAL selector switch of the D/A converter to the LOCAL position.

- * Installation work of DPO unit on to PAE series will be performed only by Kikusui.

To Use The Guard Cap

The guard cap is used to fix or semi-fix the output voltage or current control knob. (The guard cap is not applicable to dual-shaft gang-type potentiometers.)

How to use the guard cap

- (1) Remove the knob after undoing its setscrew using an L-shape wrench (Allen wrench).
- (2) Fixed type (adjustment disabled)
- (3) Semi-fixed type (adjustment with screwdriver)

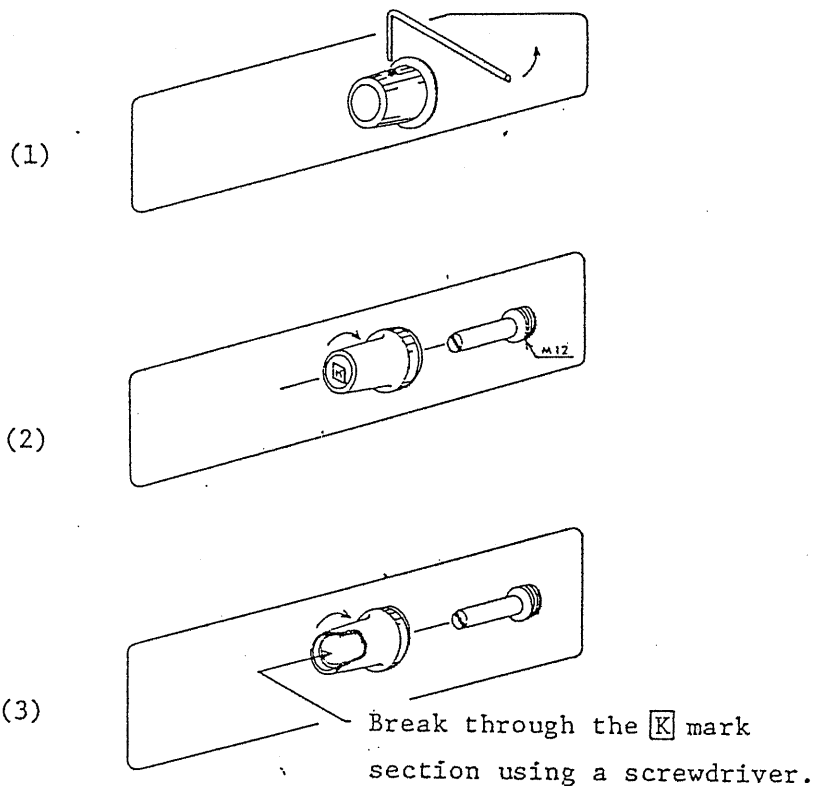

833898